

1000SR

The Powerscreen® 1000SR is built around the successful 1000 Maxtrak model and features a re-circulating conveyor and a double-deck post-screen to provide a complete crushing and screening process on a single chassis. The machine is designed for direct feed applications without pre-screening on clean rock. At its heart is the Automax® cone crusher which provides excellent reduction and product cubicity for the production of high quality aggregate and sub-base material. Hydraulic release capabilities are designed so that any uncrushable material entering the chamber is safely discharged. Suitable for secondary and tertiary applications, the 1000SR can produce up to three products when oversized material doesn't require re-circulation to the crusher.

Features & Benefits

- Renowned Automax® crusher technology
- Accepts clean all in feed
- Excellent product shape
- High reduction ratio
- Cone feed box level control to maintain choke feeding
- Hydraulic crusher setting
- Cone overload protection
- Heavy duty chassis and track frame
- Metal detector
- Dust suppression system
- Economical to operate with a highly fuel efficient direct drive system
- Patented double deck post screen.
- Suitable for re-circulating oversized material

Options

- Concaves: extra coarse, medium coarse, coarse, Autosand®
- Short throw eccentric
- Feed hopper extension plates
- Product conveyor belt weigher
- Electric refuelling pump
- Hydraulic water pump
- Radio remote control
- Urea refuelling pump
- Additional stockpiling conveyor for mid-grade product

Applications

- Sand & gravel
- Blasted rock
- River rock
- C & D waste
- Foundry waste
- Processed ores
- Processed minerals

Output Potential

Up to 230tph (253 US tph)*

Fines Conveyor

Width: 1400mm (55")
Discharge height: 3m (9' 10")
Dust suppression

Product Conveyor

Width: 800mm (32")

Crusher

Automax® cone crusher with all roller bearing design
Size (head diameter): 1000mm (39")
Concave standard: Medium coarse
Min CSS: 18mm (0.7")*
Max CSS: 36mm (1.4")*

Feed Conveyor

Width: 1000mm (39")
Over and under belt metal detector

Hopper

Wear resistant feed hopper with crash bars
Length: 3.38m (11'1")
Width: 2.5m (8'2")
Capacity: 4.4m³ (5.8yds³)

Recirculating Conveyor

Width: 500mm (19.7")

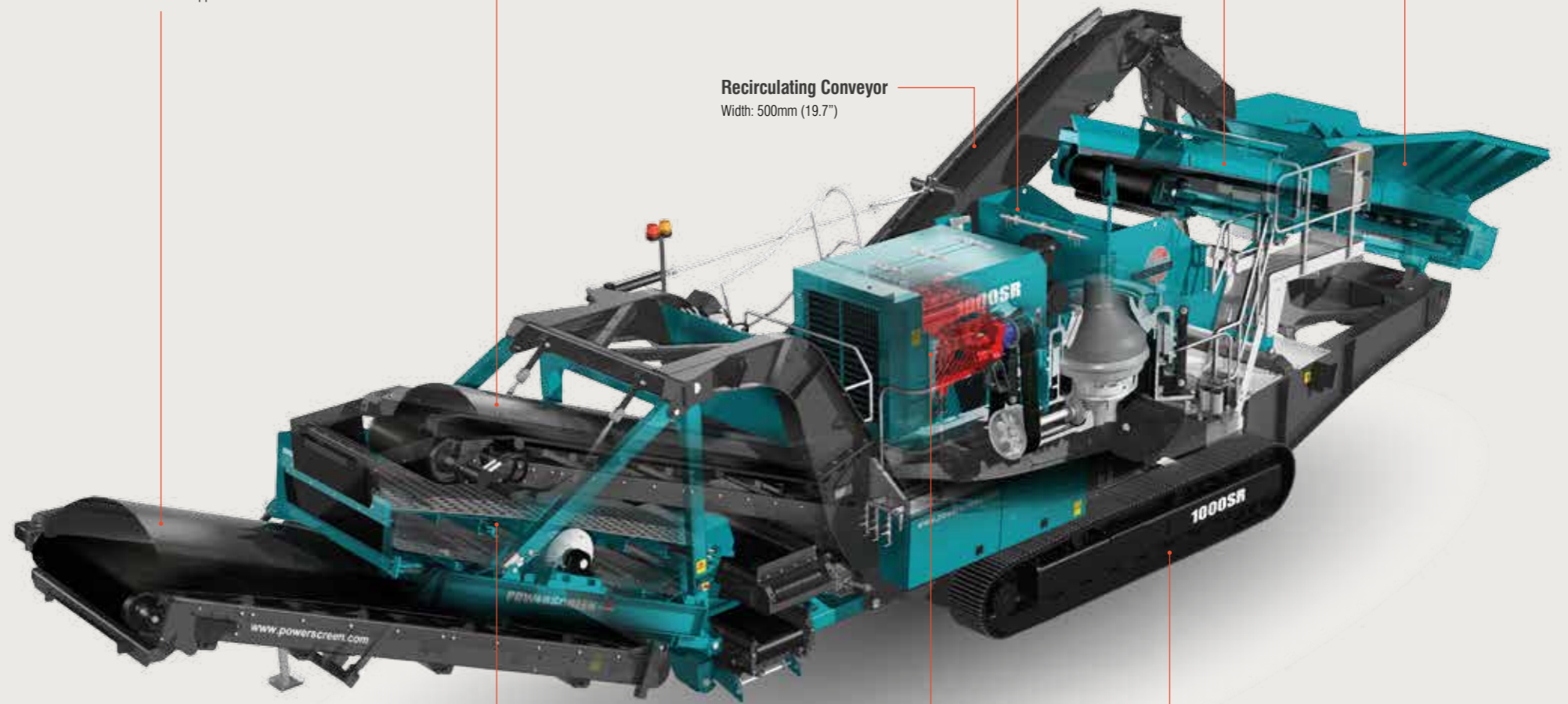

Post-Screen

2 Deck screenbox
Length: 3.35m (11')
Width: 1.525m (5')

Power Unit

Tier 3/Stage 3A:
CAT C9 ACERT 261kW (350hp)
Fuel tank capacity: 552 L (137 US Gal)
Tier 4F/Stage 4: Scania DC9 B3A 257kW (350hp)
Fuel tank capacity: 650 L (171 US Gal)

Tracks

Width: 400mm (15.7")

1000SR

Weight (Est)	39,645kg (87,391lbs)
Transport width	3.1m (10'2")
Transport length	16.9m (55'5")
Transport height	3.45m (11'4")
Working width	3.1m (10'2")
Working length	16.9m (55'5")
Working height	4.85m (15'11")



*Depends on application
Engines are available that are certified to US EPA and EU off road diesel emission standards. Talk to your dealer about possible certification options (i.e. Tier 3/Stage 3A, Tier 4/Stage 3B, Tier 4F / Stage 4).